

LMP848x Precision 76-V High-Side Current Sense Amplifiers With Voltage Output

1 Features

- Typical Values, $T_A = 25^\circ\text{C}$
- Bidirectional or Unidirectional Sensing
- Common Mode Voltage Range 4.0 V to 76 V
- Supply Voltage Range 4.5 V to 76 V
- Fixed Gains 20, 50, 60 and 100 V/V
- Gain Accuracy $\pm 0.1\%$
- Offset $\pm 80\ \mu\text{V}$
- Bandwidth (-3dB) 270 kHz
- Quiescent Current $< 100\ \mu\text{A}$
- Buffered High-Current Output $> 5\ \text{mA}$
- Input Bias Current $7\ \mu\text{A}$
- PSRR (DC) 122 dB
- CMRR (DC) 124 dB
- Temperature Range -40°C to 125°C
- 8-Pin VSSOP or 8-Pin WSON Packages

2 Applications

- High-Side Current Sense
- Vehicle Current Measurement
- Telecommunications
- Motor Controls
- Laser or LED Drivers
- Energy Management
- Solar Panel Monitoring

3 Description

The LMP8480 and LMP8481 are precision high-side current sense amplifiers that amplify a small differential voltage developed across a current sense resistor in the presence of high input common-mode voltages. These amplifiers are designed for bidirectional (LMP8481) or unidirectional (LMP8480) current applications and will accept input signals with common-mode voltage range from 4 V to 76 V with a bandwidth of 270 kHz. Since the operating power supply range overlaps the input common-mode voltage range, the LMP848x can be powered by the same voltage that is being monitored. This benefit eliminates the need for an intermediate supply voltage to be routed to the point of load where the current is being monitored, resulting in reduced component count and board space.

The LMP848x family consists of fixed gains of 20, 50, 60 and 100 for applications that demand high accuracy over temperature. The low-input offset voltage allows the use of smaller sense resistors without sacrificing system error. The wide operating temperature range of -40°C to 125°C makes the LMP848x an ideal choice for automotive, telecommunications, industrial, and consumer applications. The LMP8480 and LMP8481 are pin-for-pin replacements for the MAX4080 and MAX4081, offering improved offset voltage, wider reference adjust range and higher output drive capabilities. The LMP8480 and LMP8481 are available in a 8-pin VSSOP package and the LMP8481 is also available in a 8-pad WSON.

Typical Application Schematic

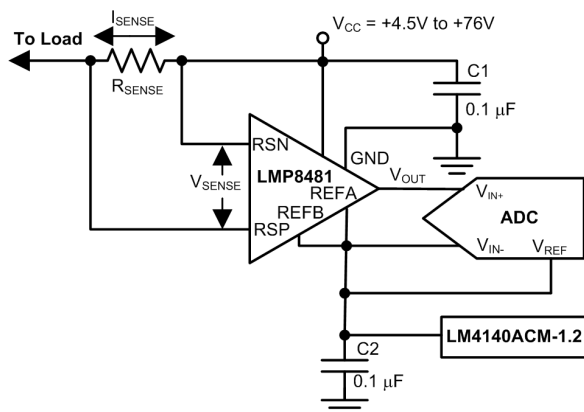

Device Information⁽¹⁾

PART NUMBER	PACKAGE	BODY SIZE (NOM)
LMP8480	VSSOP (8)	3.00 mm x 3.00 mm
	WSON (8)	
LMP8481	VSSOP (8)	3.00 mm x 3.00 mm
	WSON (8)	

(1) For all available packages, see the orderable addendum at the end of the datasheet.



Table of Contents

1 Features	1	8.4 Device Functional Modes.....	17
2 Applications	1	9 Application and Implementation	18
3 Description	1	9.1 Application Information.....	18
4 Revision History	2	9.2 Typical Applications	18
5 Device Comparison Table	3	10 Power Supply Recommendations	21
6 Pin Configuration and Functions	3	10.1 Power Supply Decoupling.....	21
7 Specifications	4	11 Layout	21
7.1 Absolute Maximum Ratings	4	11.1 Layout Guidelines	21
7.2 ESD Ratings.....	4	11.2 Layout Example	21
7.3 Recommended Operating Conditions.....	4	12 Device and Documentation Support	22
7.4 Thermal Information	4	12.1 Device Support	22
7.5 Electrical Characteristics.....	5	12.2 Related Links	22
7.6 Typical Characteristics.....	7	12.3 Trademarks	22
8 Detailed Description	10	12.4 Electrostatic Discharge Caution.....	22
8.1 Overview	10	12.5 Glossary	22
8.2 Functional Block Diagrams	11	13 Mechanical, Packaging, and Orderable	22
8.3 Feature Description.....	12	Information	22

4 Revision History

Changes from Revision A (August 2012) to Revision B

Page

- Added *Pin Configuration and Functions* section, *ESD Ratings* table, *Feature Description* section, *Device Functional Modes*, *Application and Implementation* section, *Power Supply Recommendations* section, *Layout* section, *Device and Documentation Support* section, and *Mechanical, Packaging, and Orderable Information* section **1**

5 Device Comparison Table

DEVICE NAME	GAIN	POLARITY
LMP8480-T	x20	Unidirectional
LMP8480-F	x50	Unidirectional
LMP8480-S	x60	Unidirectional
LMP8480-H	x100	Unidirectional
LMP8481-T	x20	Bidirectional or Unidirectional
LMP8481-F	x50	Bidirectional or Unidirectional
LMP8481-S	x60	Bidirectional or Unidirectional
LMP8481-H	x100	Bidirectional or Unidirectional

6 Pin Configuration and Functions

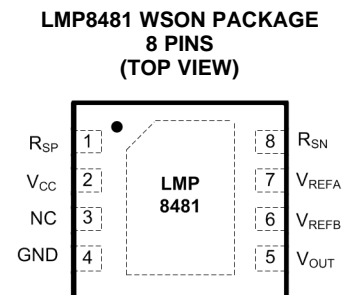
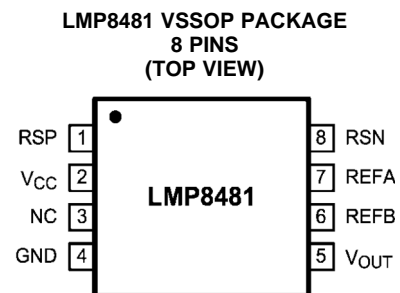
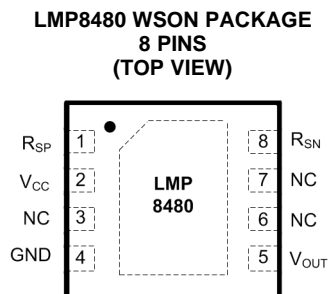
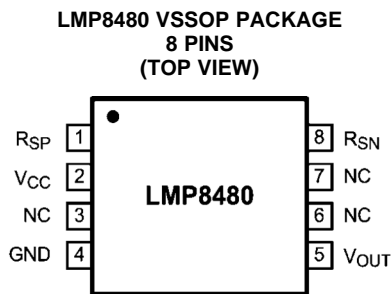

Pin Functions⁽¹⁾

PIN		I/O	DESCRIPTION	
NAME	NO.			
R _{SP}	1	I	Positive current sense input	
V _{CC}	2	P	Positive supply voltage	
NC	3	—	No Connection – Not internally Connected.	
GND	4	P	Ground	
V _{OUT}	5	O	Output	
NC or R _{EFA}	6	I	LMP8480: No Connection	LMP8481: Reference Voltage “B” Input
NC or R _{EFB}	7	I	LMP8480: No Connection	LMP8481: Reference Voltage “A” Input
R _{SN}	8	I	Negative current sense input	

(1) The bottom thermal pad of the WSON package should be tied to the same ground as the ground pin. Be aware that noise on this pad can couple into the bottom of the die, so the ground should be as clean as possible.

7 Specifications

7.1 Absolute Maximum Ratings⁽¹⁾⁽²⁾

Over operating free-air temperature range (unless otherwise noted)⁽³⁾

		MIN	MAX	UNIT
Supply Voltage (V_{CC} to GND)		-0.3	85	V
R_{SP} or R_{SN} to GND		-0.3	85	V
V_{OUT} to GND		-0.3 to the lesser of ($V_{CC} + 0.3$) or +20		V
V_{REF} Pins (LMP8481 Only)	Other V_{REF} pin tied to ground	-0.3	12	V
	Applied to both V_{REF} Pins tied together	-0.3	6	V
Differential Input Voltage		-85	85	V
Current into output pin		-20 ⁽⁴⁾	20	mA
Current into any other pins		-5 ⁽⁴⁾	5	mA
Operating Temperature		-40	125	°C
Junction Temperature		-40	150	°C
Storage temperature		-65	150	°C

- (1) The maximum power dissipation must be derated at elevated temperatures and is dictated by $T_{J(MAX)}$, θ_{JA} , and the ambient temperature, T_A . The maximum allowable power dissipation $P_{DMAX} = (T_{J(MAX)} - T_A) / \theta_{JA}$ or the number given in [Absolute Maximum Ratings](#), whichever is lower.
- (2) If Military/Aerospace specified devices are required, contact the Texas Instruments Sales Office/ Distributors for availability and specifications.
- (3) Stresses beyond those listed under [Absolute Maximum Ratings](#) may cause permanent damage to the device. These are stress ratings only, and functional operation of the device at these or any other conditions beyond those indicated under [Recommended Operating Conditions](#) is not implied. Exposure to absolute-maximum-rated conditions for extended periods may affect device reliability.
- (4) When the input voltage (V_{IN}) at any pin exceeds power supplies ($V_{IN} < GND$ or $V_{IN} > VS$), the current at that pin must not exceed 5 mA, and the voltage (V_{IN}) has to be within the [Absolute Maximum Ratings](#) for that pin. The 20-mA package input current rating limits the number of pins that can safely exceed the power supplies with current flow to four pins.

7.2 ESD Ratings

		VALUE	UNIT
$V_{(ESD)}$ Electrostatic discharge	Human-body model (HBM), per ANSI/ESDA/JEDEC JS-001 ⁽¹⁾	±2000	V
	Charged-device model (CDM), per JEDEC specification JESD22-C101 ⁽²⁾	±750	

- (1) JEDEC document JEP155 states that 500-V HBM allows safe manufacturing with a standard ESD control process.
- (2) JEDEC document JEP157 states that 250-V CDM allows safe manufacturing with a standard ESD control process.

7.3 Recommended Operating Conditions

Expected normal operating conditions over free-air temperature range (unless otherwise noted)⁽¹⁾

		MIN	MAX	UNIT
Supply Voltage (V_{CC})		4.5	76	V
Common Mode Voltage		4.0	76	V
Reference Input (LMP8481 Only)	V_{REFA} and V_{REFB} tied together	-0.3 to the lesser of ($V_{CC} - 1.5$) or +6		V
	Single V_{REF} pin with other V_{REF} pin grounded	-0.3 or +12 where the average of the two V_{REF} pins is less than the lesser of ($V_{CC} - 1.5$) or +6		V

- (1) Exceeding the [Recommended Operating Conditions](#) for extended periods of time may effect device reliability or cause parametric shifts.

7.4 Thermal Information

THERMAL METRIC ⁽¹⁾	LMP8480, LMP8481		UNIT
	DGK	NCQ	
	8 PINS		
$R_{\theta JA}$ Junction-to-ambient thermal resistance	185	70	°C/W

- (1) For more information about traditional and new thermal metrics, see the *IC Package Thermal Metrics* application report, [SPRA953](#).

7.5 Electrical Characteristics

Unless otherwise specified, all limits specified for at $T_A = 25^\circ\text{C}$, $V_{CC} = 4.5\text{ V to }76\text{ V}$, $4.5\text{V } V_{CM}$ 76 V , $R_L = 100\text{ k}$, $V_{SENSE} = (V_{RSP} - V_{RSN}) = 0\text{ V}$.⁽¹⁾

PARAMETER		TEST CONDITIONS		MIN ⁽²⁾	TYP ⁽³⁾	MAX ⁽²⁾	UNIT
V_{OS}	Input Offset Voltage (RTI)	$V_{CC} = V_{RSP} = 48\text{ V}$, $\Delta V = 100\text{ mV}$	$T_A = 25^\circ\text{C}$		± 80	± 265	μV
			$-40^\circ\text{C} \leq T_A \leq 125^\circ\text{C}$			± 900	
TCV_{OS}	Input Offset Voltage Drift ⁽⁴⁾				± 6		$\mu\text{V}^\circ\text{C}$
I_B	Input Bias Current ⁽⁵⁾	$V_{CC} = V_{RSP} = 76\text{ V}$, Per Input			6.3		μA
		$V_{CC} = V_{RSP} = 76\text{ V}$, Per Input, $-40^\circ\text{C} \leq T_A \leq 125^\circ\text{C}$				12	
I_{LEAK}	Input Leakage Current	$V_{CC} = 0$, $V_{RSP} = 86\text{ V}$, Both inputs together			0.01		μA
		$V_{CC} = 0$, $V_{RSP} = 86\text{ V}$, Both inputs together, $-40^\circ\text{C} \leq T_A \leq 125^\circ\text{C}$				2	
$V_{SENSE(MA X)}$	Differential Input Voltage Across Sense Resistor ⁽⁶⁾	$V_{CC} = 16$	-T Version, $-40^\circ\text{C} \leq T_A \leq 125^\circ\text{C}$			667	mV
			-F Version, $-40^\circ\text{C} \leq T_A \leq 125^\circ\text{C}$			267	
			-S Version, $-40^\circ\text{C} \leq T_A \leq 125^\circ\text{C}$			222	
			-H Version, $-40^\circ\text{C} \leq T_A \leq 125^\circ\text{C}$			133	
A_V	Gain	-T Version			20		V/V
		-T Version, $-40^\circ\text{C} \leq T_A \leq 125^\circ\text{C}$		19.8		20.2	
		-F Version			50		
		-F Version, $-40^\circ\text{C} \leq T_A \leq 125^\circ\text{C}$		49.6		50.4	
		-S Version			60		
		-S Version, $-40^\circ\text{C} \leq T_A \leq 125^\circ\text{C}$		59.5		60.5	
		-H Version			100		
		-H Version, $-40^\circ\text{C} \leq T_A \leq 125^\circ\text{C}$		99.2		100.8	
	Gain Error	$V_{CC} = V_{RSP} = 48\text{ V}$	$T_A = 25^\circ\text{C}$			$\pm 0.6\%$	
			$-40^\circ\text{C} \leq T_A \leq 125^\circ\text{C}$			$\pm 0.8\%$	
DC PSRR	DC Power Supply Rejection Ratio	$V_{RSP} = 48\text{ V}$, $V_{CC} = 4.5\text{ to }76\text{ V}$			122		dB
		$V_{RSP} = 48\text{ V}$, $V_{CC} = 4.5\text{ to }76\text{ V}$, $-40^\circ\text{C} \leq T_A \leq 125^\circ\text{C}$		100			
DC CMRR	DC Common Mode Rejection Ratio	$V_{CC} = 48\text{ V}$, $V_{RSP} = 4.5\text{ to }76\text{ V}$			124		dB
		$V_{CC} = 48\text{ V}$, $V_{RSP} = 4.5\text{ to }76\text{ V}$, $-40^\circ\text{C} \leq T_A \leq 125^\circ\text{C}$		100			
		$V_{CC} = 48\text{ V}$, $V_{RSP} = 4\text{ to }76\text{ V}$			124		
CMVR	Input Common Mode Voltage Range	CMRR > 100 dB, $-40^\circ\text{C} \leq T_A \leq 125^\circ\text{C}$		4		76	V
R_{OUT}	Output Resistance / Load Regulation	$V_{SENSE} = 100\text{ mV}$			0.1		
V_{OMAX}	Maximum Output Voltage (Headroom) ($V_{OMAX} = V_{CC} - V_{OUT}$)	$V_{CC} = 4.5\text{ V}$, $V_{RSP} = 48\text{ V}$, $V_{SENSE} = +1\text{ V}$, I_{OUT} (sourcing) $500\text{ }\mu\text{A}$			230	500	mV

- (1) Electrical Table values apply only for factory testing conditions at the temperature indicated. Factory testing conditions result in very limited self-heating of the device such that $T_J = T_A$. **No** specification of parametric performance is indicated in the electrical tables under conditions of internal self-heating where $T_J > T_A$.
- (2) All limits are specified by testing, design, or statistical analysis.
- (3) Typical values represent the most likely parametric norm at the time of characterization. Actual typical values may vary over time and will also depend on the application and configuration. The typical values are not tested and are not ensured on shipped production material.
- (4) Offset voltage temperature drift is determined by dividing the change in V_{OS} at the temperature extremes by the total temperature change.
- (5) Positive Bias Current corresponds to current flowing into the device.
- (6) This parameter is specified by design and/or characterization and is not tested in production.

Electrical Characteristics (continued)

Unless otherwise specified, all limits specified for at $T_A = 25^\circ\text{C}$, $V_{CC} = 4.5\text{ V to }76\text{ V}$, $4.5\text{V } V_{CM} 76\text{ V}$, $R_L = 100\text{ k}$, $V_{SENSE} = (V_{RSP} - V_{RSN}) = 0\text{ V}$.⁽¹⁾

PARAMETER	TEST CONDITIONS	MIN ⁽²⁾	TYP ⁽³⁾	MAX ⁽²⁾	UNIT
V_{OMIN} Minimum Output Voltage	$V_{CC} = V_{RSP} = 48\text{ V}$, $V_{SENSE} = -1\text{ V}$, $I_{OUT}(\text{sinking}) = 10\text{ }\mu\text{A}$		3		mV
	$V_{CC} = V_{RSP} = 48\text{ V}$, $V_{SENSE} = -1\text{ V}$, $I_{OUT}(\text{sinking}) = 10\text{ }\mu\text{A}$, $-40^\circ\text{C} \leq T_A \leq 125^\circ\text{C}$			15	
	$V_{CC} = V_{RSP} = 4.5\text{ V}$, $V_{SENSE} = -1\text{ V}$, $I_{OUT}(\text{sinking}) = 10\text{ }\mu\text{A}$		3		
	$V_{CC} = V_{RSP} = 48\text{ V}$, $V_{SENSE} = -1\text{ V}$, $I_{OUT}(\text{sinking}) = 100\text{ }\mu\text{A}$		18		
	$V_{CC} = V_{RSP} = 48\text{ V}$, $V_{SENSE} = -1\text{ V}$, $I_{OUT}(\text{sinking}) = 100\text{ }\mu\text{A}$, $-40^\circ\text{C} \leq T_A \leq 125^\circ\text{C}$			55	
	$V_{CC} = V_{RSP} = 4.5\text{ V}$, $V_{SENSE} = -1\text{ V}$, $I_{OUT}(\text{sinking}) = 100\text{ }\mu\text{A}$		18		
V_{OLOAD} Output voltage with load	$V_{CC} = 28\text{ V}$, $V_{RSP} = 28\text{ V}$, $V_{SENSE} = 600\text{ mV}$, $I_{OUT}(\text{sourcing}) = 500\text{ }\mu\text{A}$		12		V
V_{OLREG} Output Load Regulation	$V_{CC} = 20$, $V_{RSP} = 16$, $V_{OUT} = 12$, $\Delta I_L = 200\text{ na to }8\text{ mA}$		0.001%		
I_{CC} Supply Current	$V_{OUT} = 2\text{ V}$, $R_L = 10\text{ M}$, $V_{CC} = V_{RSP} = 76\text{ V}$		88		μA
	$V_{OUT} = 2\text{ V}$, $R_L = 10\text{ M}$, $V_{CC} = V_{RSP} = 76\text{ V}$, $-40^\circ\text{C} \leq T_A \leq 125^\circ\text{C}$			155	
BW –3 dB Bandwidth	$R_L = 10\text{ M}$, $C_L = 20\text{ pF}$		270		kHz
SR Slew rate ⁽⁷⁾	V_{SENSE} from 10 mV to 80 mV, $R_L = 10\text{ M}$, $C_L = 20\text{ pF}$		1		V/ μs
e_{ni} Input Referred Voltage Noise	$f = 1\text{ kHz}$		95		nV/ $\sqrt{\text{Hz}}$
t_{SETTLE} Output Settling Time to 1% of Final Value	$V_{SENSE} = 10\text{ mV to }100\text{ mV}$ and 100 mV to 10 mV		20		μs
t_{PU} Power-up Time	$V_{CC} = V_{RSP} = 48\text{ V}$, $V_{SENSE} = 100\text{ mV}$, output to 1% of final value		50		μs
$t_{RECOVERY}$ Saturation Recovery Time	Output settles to 1% of final value, the device will not experience phase reversal when overdriven.		50		μs
C_{LOAD} Max Output Capacitance Load	No sustained oscillations		500		pF

(7) The number specified is the average of rising and falling slew rates and measured at 90% to 10%.

7.6 Typical Characteristics

Unless otherwise specified, $T_A = 25^\circ\text{C}$, $V_{CC} = 4.5\text{ V to }76\text{ V}$, $4.5\text{ V} < V_{CM} < 76\text{ V}$, $R_L = 100\text{ k}$, $V_{SENSE} = (V_{RSP} - V_{RSN}) = 0\text{ V}$, for all gain options.

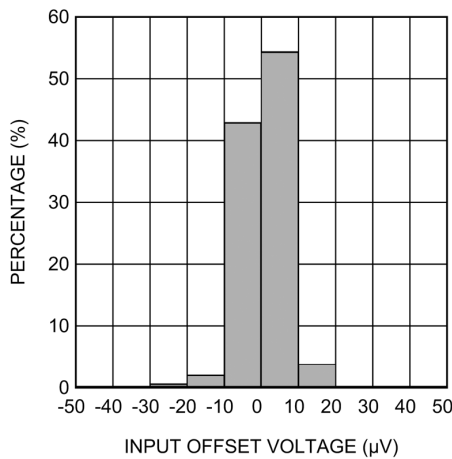

Figure 1. Offset Voltage Histogram

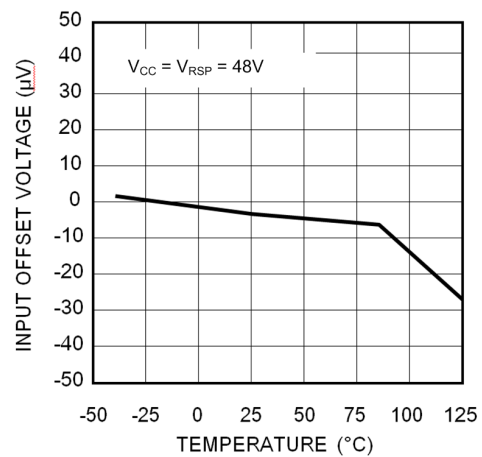

Figure 2. Typical Offset Voltage vs Temperature

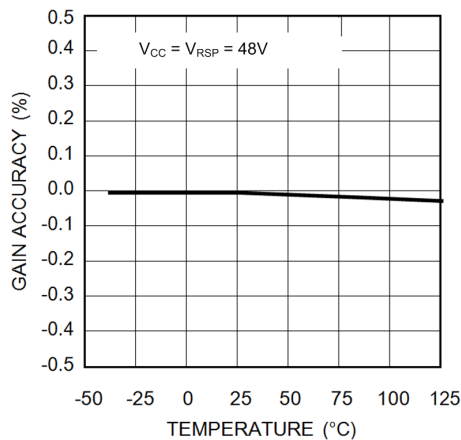

Figure 3. Typical Gain Accuracy vs Temperature

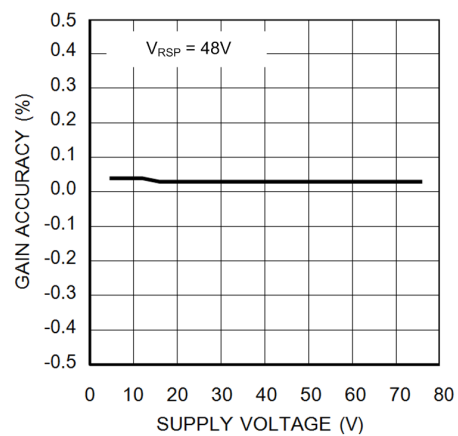

Figure 4. Typical Gain Accuracy vs Supply Voltage

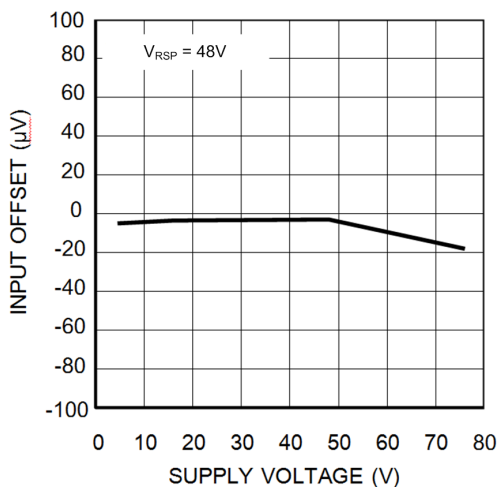

Figure 5. Typical Offset Voltage vs Supply Voltage

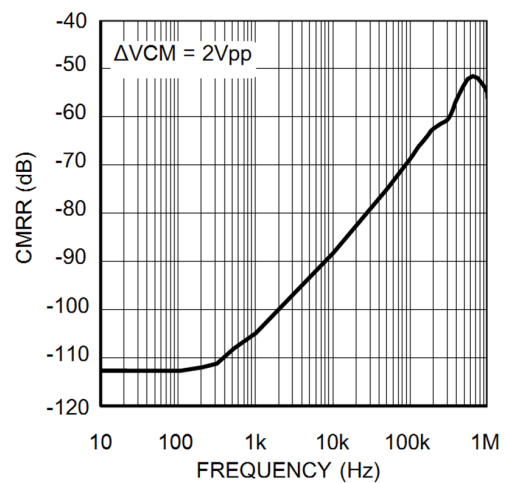

Figure 6. AC Common-Mode Rejection Ratio vs Frequency

Typical Characteristics (continued)

Unless otherwise specified, $T_A = 25^\circ\text{C}$, $V_{CC} = 4.5\text{ V to }76\text{ V}$, $4.5\text{ V} < V_{CM} < 76\text{ V}$, $R_L = 100\text{k}$, $V_{SENSE} = (V_{RSP} - V_{RSN}) = 0\text{ V}$, for all gain options.

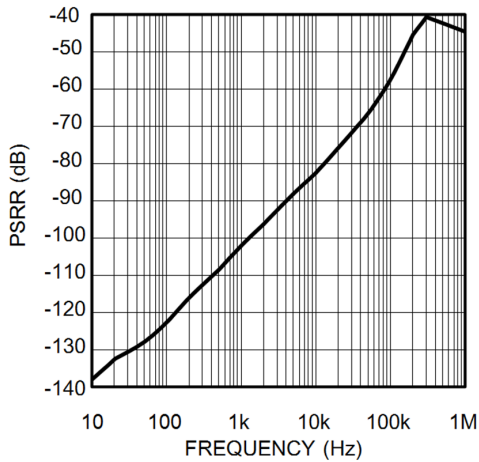

Figure 7. AC Power Supply Rejection Ratio vs Frequency

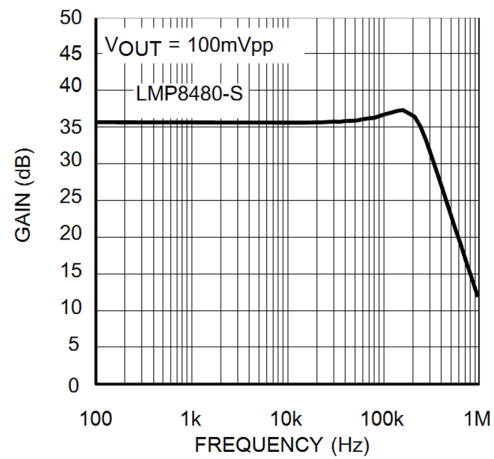

Figure 8. Small Signal Gain vs Frequency

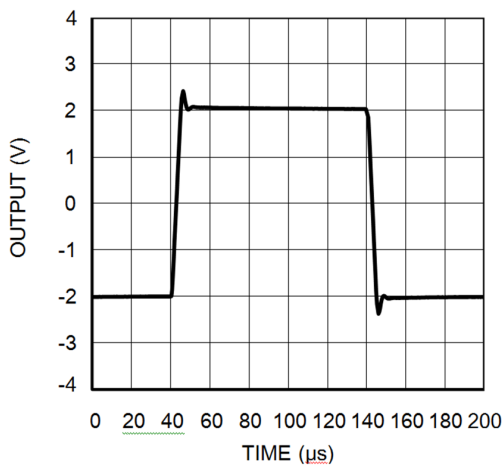

Figure 9. Large Signal Pulse Response

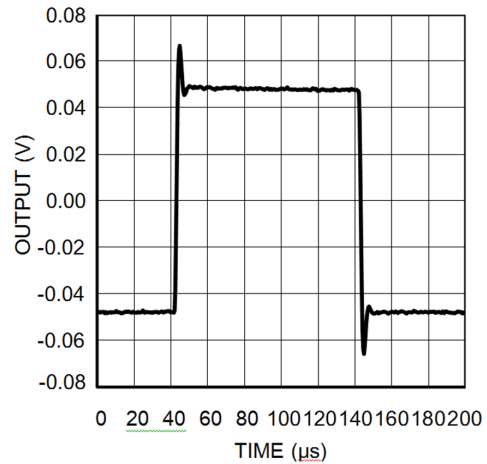

Figure 10. Small Signal Pulse Response

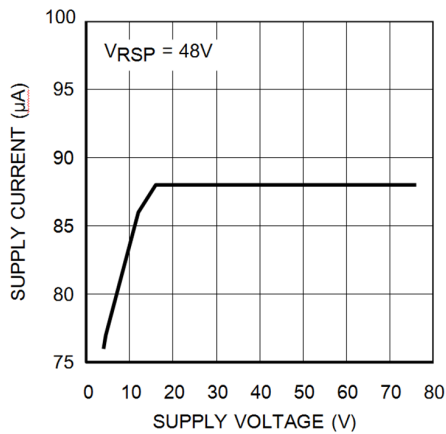

Figure 11. Supply Current vs Supply Voltage

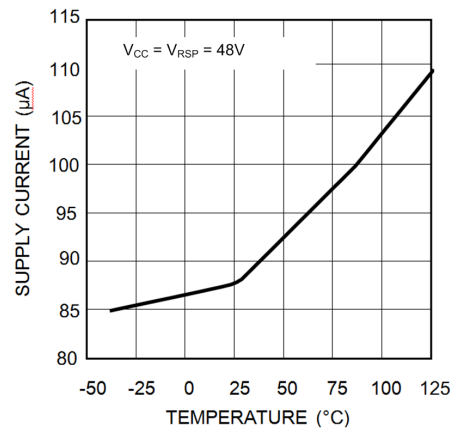

Figure 12. Supply Current vs Temperature

Typical Characteristics (continued)

Unless otherwise specified, $T_A = 25^\circ\text{C}$, $V_{CC} = 4.5\text{ V to }76\text{ V}$, $4.5\text{ V} < V_{CM} < 76\text{ V}$, $R_L = 100\text{k}$, $V_{SENSE} = (V_{RSP} - V_{RSN}) = 0\text{ V}$, for all gain options.

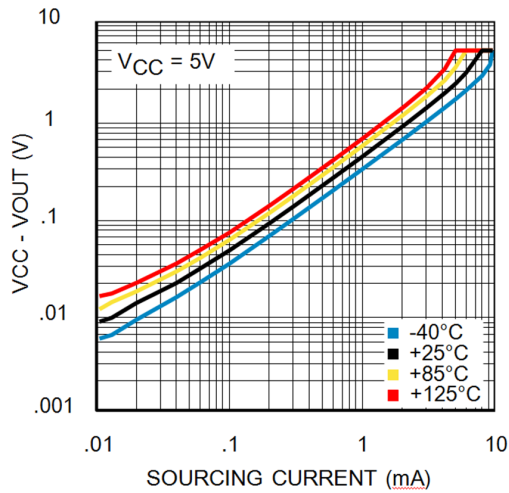

Figure 13. Saturated Output Sourcing Current at 4.5 V

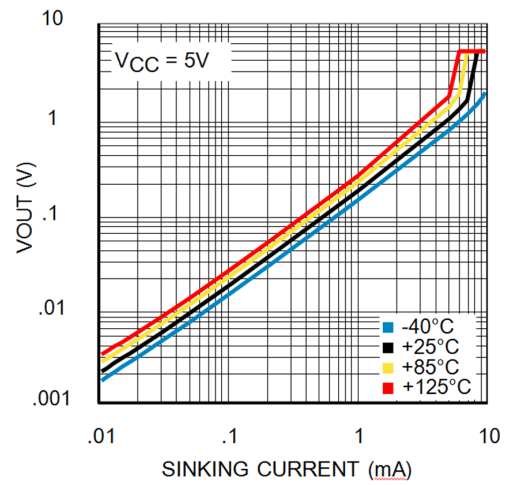

Figure 14. Saturated Output Sinking Current at 4.5 V

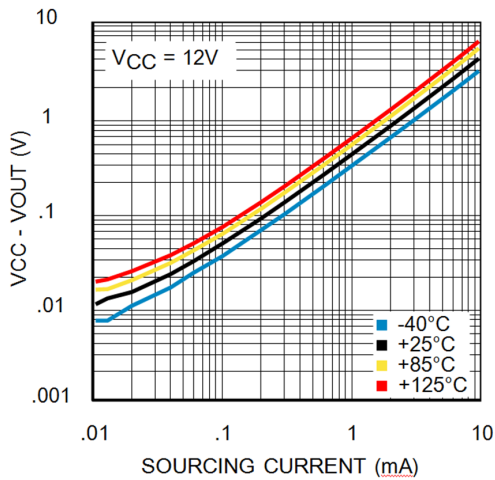

Figure 15. Saturated Output Sourcing Current at 12 V

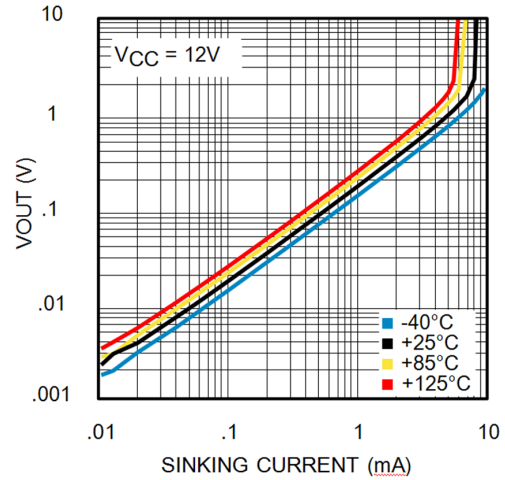

Figure 16. Saturated Output Current Sinking at 12 V

8 Detailed Description

8.1 Overview

The LMP8480 and LMP8481 are single-supply, high-side current sense amplifiers with available fixed gains of x20, x50, x60 and x100. The power supply range is 4.5 V to 76 V, while the common-mode input voltage range is capable of 4.0-V to 76-V operation. The supply voltage and common-mode range are completely independent of each other. This makes the LMP848x supply voltage extremely flexible, as the LMP848x's supply voltage can be greater than, equal to, or less than the load source voltage, and allowing the device to be powered from the system supply or the load supply voltage.

The LMP8480 and LMP8481 supply voltage does not have to be larger than the load source voltage. A 76-V load source voltage with a 5-V supply voltage is perfectly acceptable.

8.1.1 Theory of Operation

The LMP8480 and LMP8481 are comprised of two main stages. The first stage is a differential input current to voltage converter, followed by a differential voltage amplifier and level-shifting output stage. Also present is an internal 14 Volt Low-Dropout Regulator (LDO) to power the amplifiers and output stage, as well as a reference divider resistor string to allow the setting of the reference level.

As seen in [Figure 18](#), the current flowing through R_{SENSE} develops a voltage drop called V_{SENSE} . The voltage across the sense resistor, V_{SENSE} , is then applied to the input R_{SP} and R_{SN} pins of the amplifier.

Internally, the voltage on each input pin is converted to a current by the internal precision thin-film input resistors R_{GP} and R_{GN} . A second set of much higher value V_{CM} sense resistors between the inputs provide a sample of the input common-mode voltage for internal use by the differential amplifier.

V_{SENSE} is applied to the differential amplifier through R_{GP} and R_{GN} . These resistors change the input voltage to a differential current. The differential amplifier then servos the resistor currents through the MOSFETs to maintain a zero balance across the differential amplifier inputs.

With no input signal present, the currents in R_{GP} and R_{GN} are equal. When a signal is applied to V_{SENSE} , the current through R_{GP} and R_{GN} are imbalanced and are no longer equal. The amplifier then servos the MOSFETs to correct this current imbalance, and the extra current required to balance the input currents is then reflected down into the two lower 400-k Ω "tail" resistors. The difference in the currents into the tail resistors is therefore proportional to the amplitude and polarity of V_{SENSE} . The tail resistors, being larger than the input resistors for the same current, then provide voltage gain by changing the current into a proportionally larger voltage. The gain of the first stage is then set by the tail resistor value divided by R_G value.

The differential amplifier stage then samples the voltage difference across the two 400-k Ω tail resistors and also applies a further gain-of-five and output level-shifting according to the applied reference voltage (V_{REF}).

The resulting output of the amplifier will be equal to the differential input voltage times the gain of the device, plus any voltage value applied to the two VREF pins.

The resistor values in the schematic are ideal values for clarity and understanding. [Table 1](#) shows the actual values used that account for parallel combinations and loading. This table can be used for calculating the effects of any additional external resistance.

The LMP8480 is identical to the LMP8481, except that both the V_{REF} pins are grounded internally.

Table 1. Actual Internal Resistor Values

Gain Option	R_{GP} and R_{GN} (each)	$R_{VCMSENSE}$ (each)	R_{TAIL} (each)	Differential Amp FB (each)	V_{REFX} Resistors (each)
20x	98.38 k	491.9 k	393.52 k	1967.6 k	98.38 k
50x	39.352 k	196.76 k	393.52 k	1967.6 k	98.38 k
60x	32.793 k	172.165 k	393.52 k	1967.6 k	98.38 k
100x	19.676 k	98.38 k	393.52 k	1967.6 k	98.38 k

8.2 Functional Block Diagrams

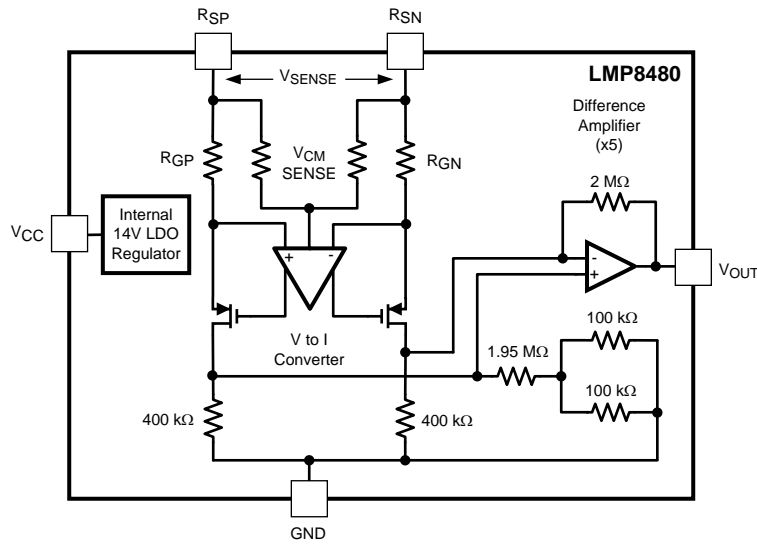

Figure 17. LMP8480 Block Diagram

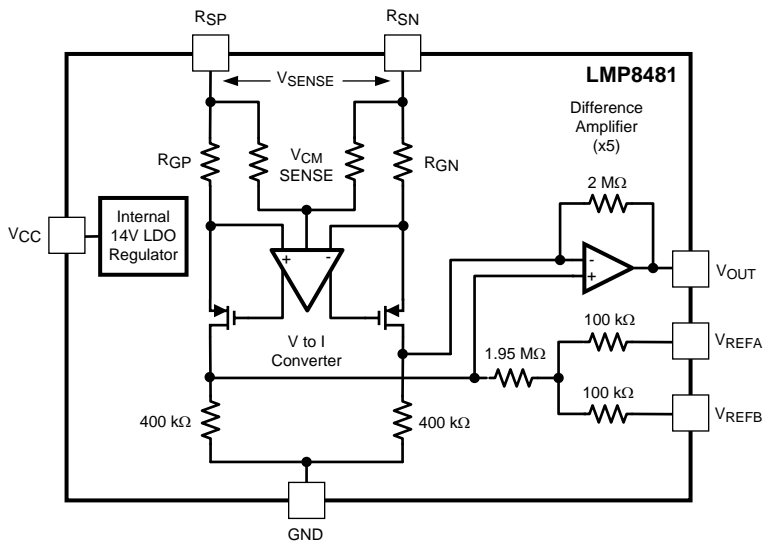

Figure 18. LMP8481 Block Diagram

8.3 Feature Description

8.3.1 Basic Connections

Figure 19 through Figure 22 show the basic connections for several different configurations.

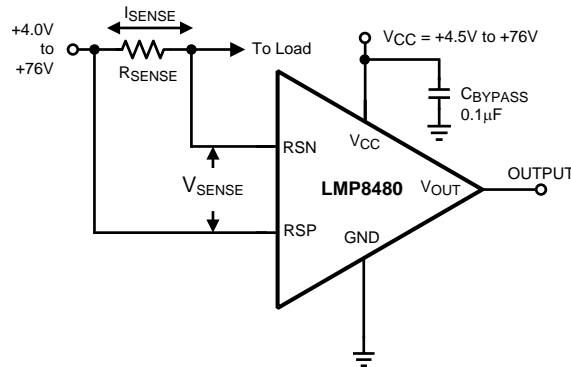

Figure 19. LMP8480 Basic Connections (Unidirectional)

Figure 19 shows the basic connections for the LMP8480 for Unidirectional applications. The output will be at zero with zero sense voltage.

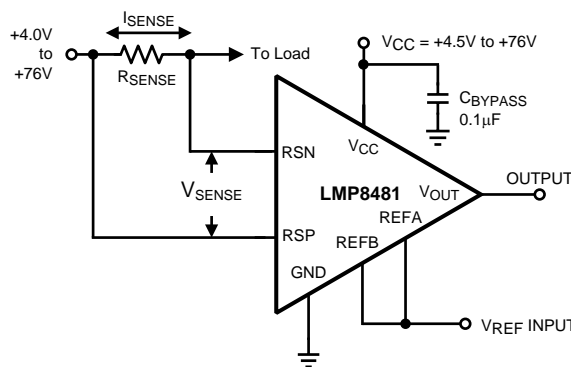

Figure 20. LMP8481 Basic Connections for External 1:1 V_{REF} Input (Bidirectional)

Figure 20 shows the basic connections for the LMP8481 for Bidirectional applications using an external reference input. At zero input voltage, the output will be at the applied reference voltage (V_{REF}), moving positive or negative from the zero reference point.

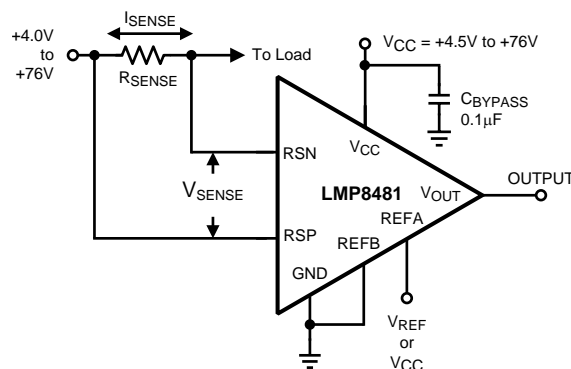

Figure 21. LMP8481 Basic Connections for Mid-Bias ($V_{REF}/2$) Input (Bidirectional)

Feature Description (continued)

Figure 21 shows the basic connections for the LMP8481 for Bidirectional applications centering the output at one-half the applied V_{REF} or V_{CC} voltage. If V_{REFA} is connected to V_{CC} , then the output "zero" point will be $V_{CC}/2$. If V_{REFA} is connected to the ADC V_{REF} line, then the "zero" output will be at mid-scale for the ADC.

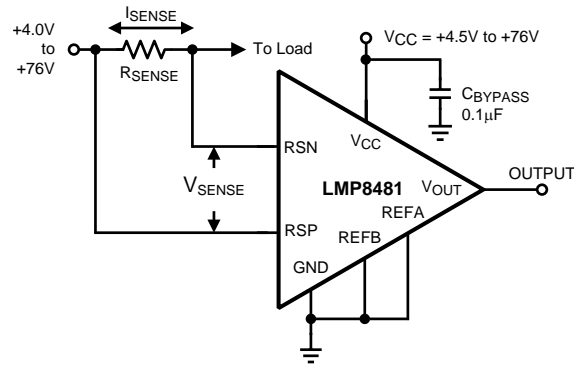

Figure 22. LMP8481 Connections for Unidirectional Configuration (Equivalent to LMP8480 Unidirectional)

Figure 22 shows the how to connect the LMP8481 for Bidirectional applications, thus making it equivalent to the LMP8480 in Figure 19.

8.3.2 Selection of the Sense Resistor

The accuracy of the current measurement depends heavily on the accuracy of the shunt resistor R_{SENSE} . Its value depends on the application and is a compromise between small-signal accuracy, maximum permissible voltage drop and allowable power dissipation in the current measurement circuit.

The use of a "4-terminal" or "Kelvin" sense resistor is highly recommended. See the [Layout Guidelines](#).

For best results, the value of the resistor is calculated from the maximum expected load current I_{LMAX} and the expected maximum output swing V_{OUTMAX} , plus a few percent of headroom. See the [Maximum Output Voltage](#) section for details about the maximum output voltage limits.

High values of R_{SENSE} provide better accuracy at lower currents by minimizing the effects of amplifier offset. Low values of R_{SENSE} minimize load voltage loss, but at the expense of accuracy at low currents. A compromise between low current accuracy and load circuit losses must generally be made.

The maximum V_{SENSE} voltage that must be generated across the R_{SENSE} resistor will be:

$$V_{SENSE} = V_{OUTMAX} / A_v \quad (1)$$

NOTE

The maximum V_{SENSE} voltage should be no more than 667 mV.

From this maximum V_{SENSE} voltage, the R_{SENSE} value can be calculated from:

$$R_{SENSE} = V_{SENSE} / I_{LMAX} \quad (2)$$

Take care not exceed the maximum power dissipation of the resistor. The maximum sense resistor power dissipation will be:

$$P_{RSENSE} = V_{SENSE} \times I_{LMAX} \quad (3)$$

TI recommends using a 2-3x minimum safety margin in selecting the power rating of the resistor.

8.3.3 Using PCB Traces as Sense Resistors

While it may be tempting to use a known length of PCB trace resistance as a sense resistor, it is not recommended.

The temperature coefficient of copper is typically 3300-4000 ppm/ $^{\circ}$ K, which can vary over PCB process variations and require measurement correction (possibly requiring ambient temperature measurements).

Feature Description (continued)

A typical surface mount sense resistor tempco is in the 50 ppm to 500 ppm/°C range offering more measurement consistency and accuracy over the copper trace. Special low-tempco resistors are available in the 0.1 to 50 ppm range, but at a higher cost.

8.3.4 V_{REFA} and V_{REFB} Pins (LMP8481 Only)

The voltage applied to the V_{REFA} and V_{REFB} pins controls the output zero reference level. Depending on how the pins are configured, the output reference level can be set to GND, or $V_{CC}/2$, or external $V_{REF}/2$, or the average of two different input references.

The reference inputs consist of a pair of divider resistors with equal values to a common summing point, V_{REF}' as shown in [Figure 23](#). Assuming V_{SENSE} is zero, the output will be at the same value as V_{REF}' .

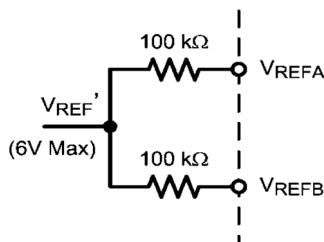

Figure 23. V_{REF} Input Resistor Network

V_{REF}' is the voltage at the resistor tap-point that will be directly applied to the output as an offset. With the two V_{REF} inputs tied together, the output zero voltage will have a 1:1 ratio relationship with V_{REF}' .

$$V_{OUT} = ((V_{RSP} - V_{RSN}) \times Av) + V_{REF}' \quad (4)$$

Where:

$$V_{REF}' = V_{REFA} = V_{REFB} \text{ (Equal Inputs)} \quad (5)$$

or:

$$V_{REF}' = (V_{REFA} + V_{REFB}) / 2 \text{ (Different Inputs)} \quad (6)$$

8.3.4.1 One-to-One (1:1) Reference Input

To directly set the reference level, the two inputs are connected to the external reference voltage. The applied V_{REF} will be reflected 1:1 on the output.

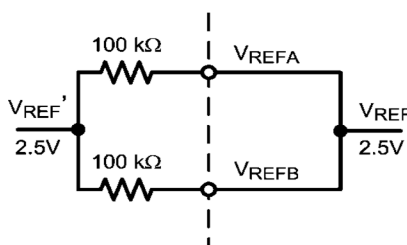

Figure 24. Applying 1:1 Direct Reference Voltage

Feature Description (continued)

8.3.4.2 Setting Output to One-Half V_{CC} or external V_{REF}

For mid-range operation V_{REFB} should be tied to ground and V_{REFA} can be tied to V_{CC} or an external A/D reference voltage. The output will be set to one-half the reference voltage. For example, a 5-V reference would result in a 2.5-V output “zero” reference.

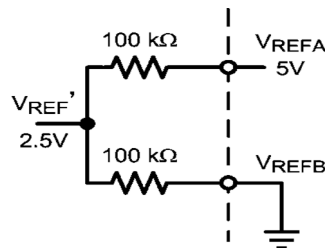

Figure 25. Applying a Divided Reference Voltage

$$V_{REF'} = (V_{REFA} - V_{REFB}) / 2 \quad (7)$$

When the reference pins are biased at different voltages, the output will be referenced to the average of the two applied voltages.

The reference pins should always be driven from clean, stable sources, such as A/D reference lines or clean supply lines. Any noise or drifts on the reference inputs are directly reflected in the output. Take care if the power supply is used as the reference source so as to not introduce supply noise, drift or sags into the measurement.

It is possible to set different resistor divider ratios by adding external resistors in series with the internal 100-K resistors, though the temperature coefficient (tempco) of the external resistors may not tightly track the internal resistors and there will be slight errors over temperature.

The LMP8480 is identical to the LMP8481, except that both the V_{REF} pins are grounded internally. The LMP8481 can replace the LMP8480 if both V_{REF} pins are grounded.

8.3.5 Reference Input Voltage Limits (LMP8481 Only)

The maximum voltage on either reference input pin is limited to V_{CC} or 12 V, whichever is less.

The average voltage on the two V_{REF} pins, and thus the actual output reference voltage level, is limited to a maximum of 1.5 V below V_{CC} , or 6 V, whichever is less. Beware that supply voltages of less than 7.5 V will have a diminishing V_{REF} maximum.

Both V_{REFA} and V_{REFB} may both be grounded to provide a ground referenced output (thus functionally duplicating the LMP8480).

It should be noted that there can be a dynamic error in the V_{REF} to output level matching of up to 100 $\mu\text{V}/\text{V}$. Normally this is not an issue for fixed references, but if the reference voltage is dynamically adjusted during operation, this error needs to be taken into account during calibration routines. This error will vary in both amplitude and polarity part-to-part, but the slope will generally be linear.

8.3.6 Low-Side Current Sensing

The LMP8480 and LMP8481 are not recommended for low-side current sensing at ground level. The voltage on either input pin must be a minimum of 4.0 V above the ground pin for proper operation. The output level may not be valid for common-mode voltages below 4 V. This should be taken into consideration for monitoring or feedback applications where the load-supply voltage may dip below 4 V or be switched completely off.

Feature Description (continued)

8.3.7 Input Series Resistance

Because the input stage uses precision resistors to convert the voltage on the input pin to a current, any resistance added in series with the input pins will change the gain. If a resistance is added in series with an input, the gain of that input will not track that of the other input, causing a constant gain error.

TI does not recommend using external resistances to alter the gain, as external resistors will not have the same thermal matching as the internal thin film resistors.

If resistors are purposely added for filtering, resistance should be added equally to both inputs and the user should be aware that the gain will change slightly. See the end of the [Theory of Operation](#) section for the internal resistor values. External resistances should be kept below 10 ohms.

8.3.8 Minimum Output Voltage

The amplifier output cannot swing to exactly 0 V. There will always be a minimum output voltage set by the output transistor saturation and input offset errors. This will create a minimum output swing around the zero current reading due to the output saturation. The user should be aware of this when designing any servo loops or data acquisition systems that may assume 0 V = 0 A. If a true zero is required, the LMP8481 should be used with a VREF set slightly above ground (> 50 mV). See the [Swinging Output Below Ground](#) section for a possible solution to this issue.

8.3.9 Swinging Output Below Ground

If a negative supply is available, a pulldown resistor can be added from the output to the negative voltage to allow the output to swing a few millivolts below ground. This will now allow the ADC to resolve true zero and recover codes that would normally be lost to the negative output saturation limit.

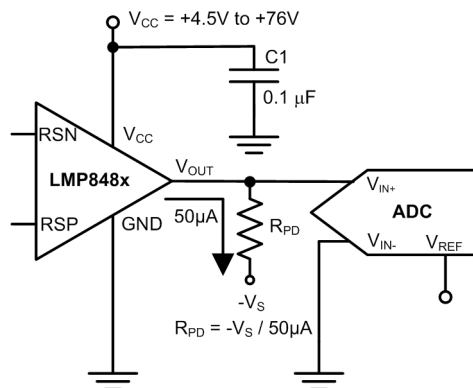

Figure 26. Output Pulldown Resistor Example

A minimum of 50 µA should be sourced (“pulled”) from the output to a negative voltage. The pulldown resistor can be calculated from:

$$R_{PD} = -V_S / 50 \mu A \quad (8)$$

For example, if a –5-V supply is available, a pulldown resistor of 5 V/50 µA = 100 kΩ should be used. This will allow the output to swing to about 10 mV below ground.

This technique may also reduce the maximum positive swing voltage. Do not forget to include the parallel loading effects of the pulldown any output load. TI recommends not to exceed –100 mV on the output. Source currents greater than 100 µA should be avoided to prevent self-heating at high-supply voltages. Pulldown resistor values should not be so low as to heavily load the output during positive output excursions. This mode of operation is not directly specified and is not ensured.

Feature Description (continued)

8.3.10 Maximum Output Voltage

The LMP8481 has an internal precision 14-V low-dropout regulator which limits the maximum amplifier output swing to about 250 mV below V_{CC} or 13.7 V (whichever is less). This effectively clamps the maximum output to slightly less than 13.7 V even with a V_{CC} greater than 14 V. See [Typical Application With Resistive Divider](#) for more information.

8.4 Device Functional Modes

8.4.1 Unidirectional vs Bidirectional Operation

Unidirectional operation is where the load current only flows in one direction (V_{SENSE} is always positive). Application examples would be PA monitoring, non-inductive load monitoring and laser or LED drivers. This allows the output zero reference to be true zero volts on the output. The LMP8480 is designed for unidirectional applications where the setting of VREF is not required. See the [Unidirectional Application With LMP8480](#) for more details.

Bidirectional operation is where the load current can flow in both directions (V_{SENSE} can be positive or negative). Application examples would be battery-charging or regenerative motor monitoring. The LMP8481 is designed for bidirectional applications and has a pair of VREF pins to allow the setting of the output zero reference level (V_{REF}). See the [Unidirectional Application With LMP8480](#) section for more details.

9 Application and Implementation

NOTE

Information in the following applications sections is not part of the TI component specification, and TI does not warrant its accuracy or completeness. TI's customers are responsible for determining suitability of components for their purposes. Customers should validate and test their design implementation to confirm system functionality.

9.1 Application Information

The LMP848x amplifies the voltage developed across a current-sensing resistor when current passes through it. Flexible offset inputs allow adjusting the functionality of the output for multiple configurations, as discussed throughout this section.

9.1.1 Input Common-Mode and Differential Voltage Range

The input common-mode range, where “common-mode range” is defined as the voltage from ground to the voltage on R_{SP} input, should be in the range of 4.0 V to 76 V. Operation below 4.0 V on either input pin will introduce severe gain error and nonlinearities.

The maximum differential voltage (defined as the voltage difference between R_{SP} and R_{SN}) should be 667 mV or less. The theoretical maximum input is 700 mV ($14\text{ V} / 20$).

Taking the inputs below 4 V will not damage the device, but the output conditions during this time are not predictable and are not ensured.

If the load voltage (V_{cm}) is expected to fall below 4 V as part of normal operation, preparations must be made for invalid output levels during this time.

9.2 Typical Applications

9.2.1 Unidirectional Application With LMP8480

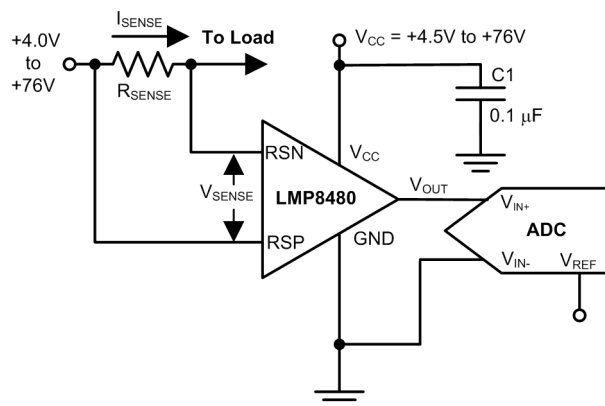

Figure 27. Unidirectional Application with LMP8480

9.2.1.1 Design Requirements

The LMP8480 is designed for unidirectional current sense applications. The output of the amplifier will be equal to the differential input voltage times the fixed device gain.

9.2.1.2 Detailed Design Procedure

The output voltage can be calculated from:

$$V_{OUT} = (V_{RSP} - V_{RSN}) \times A_V \quad (9)$$

Typical Applications (continued)

It should be noted that the minimum “zero” reading will be limited by the lower output swing and input offset. The LMP8480 is functionally identical to the LMP8481, but with the V_{REFA} and V_{REFB} nodes grounded internally. The LMP8481 can replace the LMP8480 if both the V_{REF} inputs (pins 6 and 7) are grounded.

9.2.1.3 Application Curve

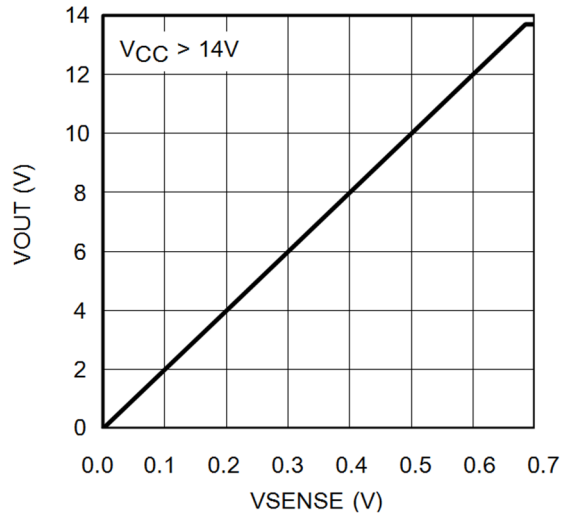

Figure 28. Unidirectional Transfer Function for Gain-of-20 Option

9.2.2 Bidirectional Current Sensing Using LMP8481

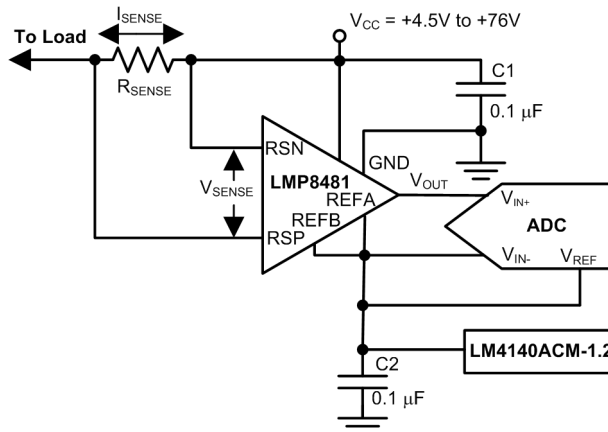

Figure 29. Bidirectional Current Sensing Using LMP8481

9.2.2.1 Design Requirements

Bidirectional operation is required where the measured load current can be positive or negative. Because V_{SENSE} can be positive or negative, and the output cannot swing negative, the “zero” output level must be level-shifted above ground to a known zero reference point. The LMP8481 allows for the setting this reference point.

9.2.2.2 Detailed Design Procedure

The V_{REFA} and V_{REFB} pins set the zero reference point. The output “zero” reference point is set by applying a voltage to the REFA and/or REFB pins. See the [Unidirectional Application With LMP8480](#) section. [V_{REFA} and V_{REFB} Pins \(LMP8481 Only\)](#) shows the output transfer function with a 1.2-V reference applied to the Gain-of-20 option.

Typical Applications (continued)

9.2.2.3 Application Curve

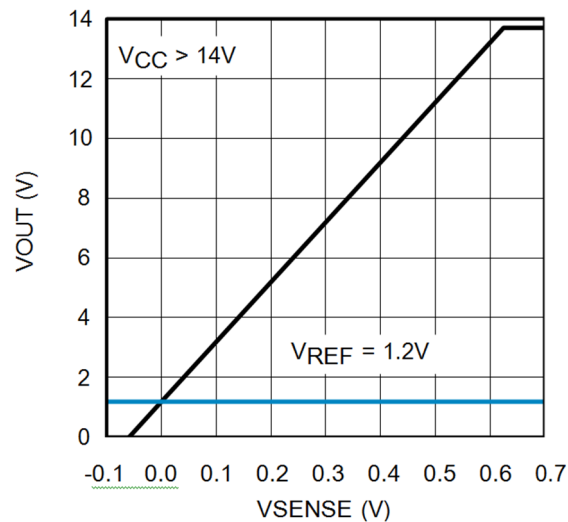

Figure 30. Bidirectional Transfer Function Using 1.2-V Reference Voltage

9.2.3 Typical Application With Resistive Divider

Take care if the output is driving an A/D input with a maximum A/D maximum input voltage lower than the amplifier supply voltage, as the output can swing higher than the planned load maximum due to input transients or shorts on the load and overload or possibly damage the A/D input.

A resistive attenuator, as shown in [Figure 31](#), can be used to match the maximum swing to the input range of the A/D.

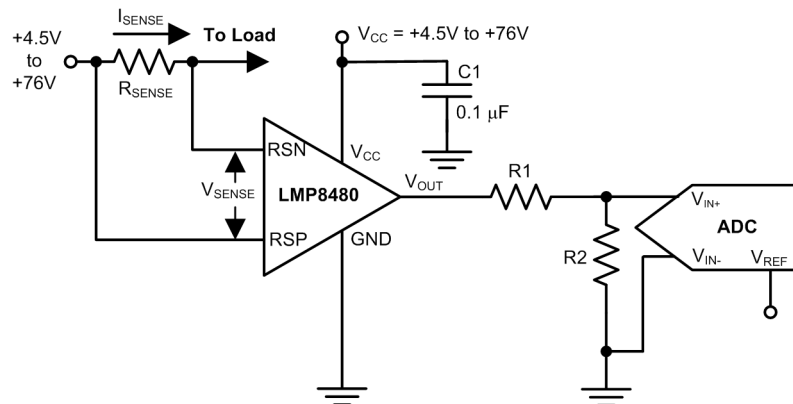

Figure 31. Typical Application With Resistive Divider Example

10 Power Supply Recommendations

10.1 Power Supply Decoupling

In order to decouple the LMP848x from AC noise on the power supply, TI recommends using a 0.1- μF bypass capacitor between the V_{CC} and GND pins. This capacitor should be placed as close as possible to the supply pins. In some cases, an additional 10- μF bypass capacitor may further reduce the supply noise.

Do not forget that these bypass capacitors must be rated for the full supply and / or load source voltage. TI recommends that the working voltage of the capacitor (WVDC) should be at least two times the maximum expected circuit voltage.

11 Layout

11.1 Layout Guidelines

The traces leading to and from the sense resistor can be significant error sources. With small value sense resistors ($< 100 \text{ m}\Omega$), any trace resistance shared with the load current can cause significant errors.

The amplifier inputs should be directly connected to the sense resistor pads using “Kelvin” or “4-wire” connection techniques. The traces should be one continuous piece of copper from the sense resistor pad to the amplifier input pin pad, and ideally on the same copper layer with minimal vias or connectors. This can be important around the sense resistor if it is generating any significant heat gradients.

To minimize noise pickup and thermal errors, the input traces should be treated as a differential signal pair and routed tightly together with a direct path to the input pins. The input traces should be run away from noise sources, such as digital lines, switching supplies or motor drive lines. Remember that these traces can contain high voltage, and should have the appropriate trace routing clearances.

Since the sense traces only carry the amplifier bias current (about 7 μA at room temperature), the connecting input traces can be thinner, signal level traces. Excessive Resistance in the trace should also be avoided.

The paths of the traces should be identical, including connectors and vias, so that these errors will be equal and cancel.

The sense resistor will heat up as the load increases. As the resistor heats up, the resistance generally goes up, which will cause a change in the readings. The sense resistor should have as much heatsinking as possible to remove this heat through the use of heatsinks or large copper areas coupled to the resistor pads. A reading drifting over time after turn-on can usually be traced back to sense resistor heating.

11.2 Layout Example

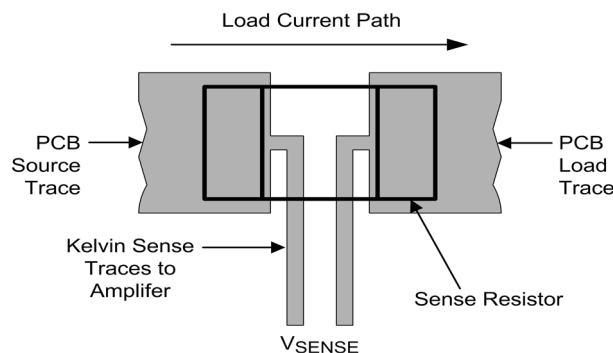

Figure 32. “Kelvin” or “4-wire” Connection to the Sense Resistor

12 Device and Documentation Support

12.1 Device Support

12.1.1 Development Support

LMP8480/1 PSPICE Model, [SNVM046](#)

LMP8480/1 TINA Reference Design, [SNVM048](#)

TINA-TI SPICE-Based Analog Simulation Program, <http://www.ti.com/tool/tina-ti>

LMP8480/1 Evaluation Boards, [product pages](#)

LMP8480/1 Evaluation Board Manual, [SNOU031](#)

12.2 Related Links

The table below lists quick access links. Categories include technical documents, support and community resources, tools and software, and quick access to sample or buy.

Table 2. Related Links

PARTS	PRODUCT FOLDER	SAMPLE & BUY	TECHNICAL DOCUMENTS	TOOLS & SOFTWARE	SUPPORT & COMMUNITY
LMP8480	Click here	Click here	Click here	Click here	Click here
LMP8481	Click here	Click here	Click here	Click here	Click here

12.3 Trademarks

All trademarks are the property of their respective owners.

12.4 Electrostatic Discharge Caution



These devices have limited built-in ESD protection. The leads should be shorted together or the device placed in conductive foam during storage or handling to prevent electrostatic damage to the MOS gates.

12.5 Glossary

[SLYZ022](#) — *TI Glossary*.

This glossary lists and explains terms, acronyms, and definitions.

13 Mechanical, Packaging, and Orderable Information

The following pages include mechanical, packaging, and orderable information. This information is the most current data available for the designated devices. This data is subject to change without notice and revision of this document. For browser-based versions of this data sheet, refer to the left-hand navigation.

PACKAGING INFORMATION

Orderable Device	Status (1)	Package Type	Package Drawing	Pins	Package Qty	Eco Plan (2)	Lead/Ball Finish (6)	MSL Peak Temp (3)	Op Temp (°C)	Device Marking (4/5)	Samples
LMP8480MM-T/NOPB	ACTIVE	VSSOP	DGK	8	1000	Green (RoHS & no Sb/Br)	CU SN	Level-1-260C-UNLIM	-40 to 125	AV8A	Samples
LMP8480MME-S/NOPB	ACTIVE	VSSOP	DGK	8	250	Green (RoHS & no Sb/Br)	CU SN	Level-1-260C-UNLIM	-40 to 125	AY8A	Samples
LMP8480MME-T/NOPB	ACTIVE	VSSOP	DGK	8	250	Green (RoHS & no Sb/Br)	CU SN	Level-1-260C-UNLIM	-40 to 125	AV8A	Samples
LMP8480MMX-S/NOPB	ACTIVE	VSSOP	DGK	8	3500	Green (RoHS & no Sb/Br)	CU SN	Level-1-260C-UNLIM	-40 to 125	AY8A	Samples
LMP8480MMX-T/NOPB	ACTIVE	VSSOP	DGK	8	3500	Green (RoHS & no Sb/Br)	CU SN	Level-1-260C-UNLIM	-40 to 125	AV8A	Samples
LMP8481MM-H/NOPB	ACTIVE	VSSOP	DGK	8	1000	Green (RoHS & no Sb/Br)	CU SN	Level-1-260C-UNLIM	-40 to 125	AH9A	Samples
LMP8481MM-S/NOPB	ACTIVE	VSSOP	DGK	8	1000	Green (RoHS & no Sb/Br)	CU SN	Level-1-260C-UNLIM	-40 to 125	AA9A	Samples
LMP8481MM-T/NOPB	ACTIVE	VSSOP	DGK	8	1000	Green (RoHS & no Sb/Br)	CU SN	Level-1-260C-UNLIM	-40 to 125	AT9A	Samples
LMP8481MME-H/NOPB	ACTIVE	VSSOP	DGK	8	250	Green (RoHS & no Sb/Br)	CU SN	Level-1-260C-UNLIM	-40 to 125	AH9A	Samples
LMP8481MME-S/NOPB	ACTIVE	VSSOP	DGK	8	250	Green (RoHS & no Sb/Br)	CU SN	Level-1-260C-UNLIM	-40 to 125	AA9A	Samples
LMP8481MME-T/NOPB	ACTIVE	VSSOP	DGK	8	250	Green (RoHS & no Sb/Br)	CU SN	Level-1-260C-UNLIM	-40 to 125	AT9A	Samples
LMP8481MMX-H/NOPB	ACTIVE	VSSOP	DGK	8	3500	Green (RoHS & no Sb/Br)	CU SN	Level-1-260C-UNLIM	-40 to 125	AH9A	Samples
LMP8481MMX-S/NOPB	ACTIVE	VSSOP	DGK	8	3500	Green (RoHS & no Sb/Br)	CU SN	Level-1-260C-UNLIM	-40 to 125	AA9A	Samples
LMP8481MMX-T/NOPB	ACTIVE	VSSOP	DGK	8	3500	Green (RoHS & no Sb/Br)	CU SN	Level-1-260C-UNLIM	-40 to 125	AT9A	Samples

(1) The marketing status values are defined as follows:

ACTIVE: Product device recommended for new designs.

LIFEBUY: TI has announced that the device will be discontinued, and a lifetime-buy period is in effect.

NRND: Not recommended for new designs. Device is in production to support existing customers, but TI does not recommend using this part in a new design.

PREVIEW: Device has been announced but is not in production. Samples may or may not be available.

OBSOLETE: TI has discontinued the production of the device.

(2) Eco Plan - The planned eco-friendly classification: Pb-Free (RoHS), Pb-Free (RoHS Exempt), or Green (RoHS & no Sb/Br) - please check <http://www.ti.com/productcontent> for the latest availability information and additional product content details.

TBD: The Pb-Free/Green conversion plan has not been defined.

Pb-Free (RoHS): TI's terms "Lead-Free" or "Pb-Free" mean semiconductor products that are compatible with the current RoHS requirements for all 6 substances, including the requirement that lead not exceed 0.1% by weight in homogeneous materials. Where designed to be soldered at high temperatures, TI Pb-Free products are suitable for use in specified lead-free processes.

Pb-Free (RoHS Exempt): This component has a RoHS exemption for either 1) lead-based flip-chip solder bumps used between the die and package, or 2) lead-based die adhesive used between the die and leadframe. The component is otherwise considered Pb-Free (RoHS compatible) as defined above.

Green (RoHS & no Sb/Br): TI defines "Green" to mean Pb-Free (RoHS compatible), and free of Bromine (Br) and Antimony (Sb) based flame retardants (Br or Sb do not exceed 0.1% by weight in homogeneous material)

(3) MSL, Peak Temp. - The Moisture Sensitivity Level rating according to the JEDEC industry standard classifications, and peak solder temperature.

(4) There may be additional marking, which relates to the logo, the lot trace code information, or the environmental category on the device.

(5) Multiple Device Markings will be inside parentheses. Only one Device Marking contained in parentheses and separated by a "~" will appear on a device. If a line is indented then it is a continuation of the previous line and the two combined represent the entire Device Marking for that device.

(6) Lead/Ball Finish - Orderable Devices may have multiple material finish options. Finish options are separated by a vertical ruled line. Lead/Ball Finish values may wrap to two lines if the finish value exceeds the maximum column width.

Important Information and Disclaimer: The information provided on this page represents TI's knowledge and belief as of the date that it is provided. TI bases its knowledge and belief on information provided by third parties, and makes no representation or warranty as to the accuracy of such information. Efforts are underway to better integrate information from third parties. TI has taken and continues to take reasonable steps to provide representative and accurate information but may not have conducted destructive testing or chemical analysis on incoming materials and chemicals. TI and TI suppliers consider certain information to be proprietary, and thus CAS numbers and other limited information may not be available for release.

In no event shall TI's liability arising out of such information exceed the total purchase price of the TI part(s) at issue in this document sold by TI to Customer on an annual basis.

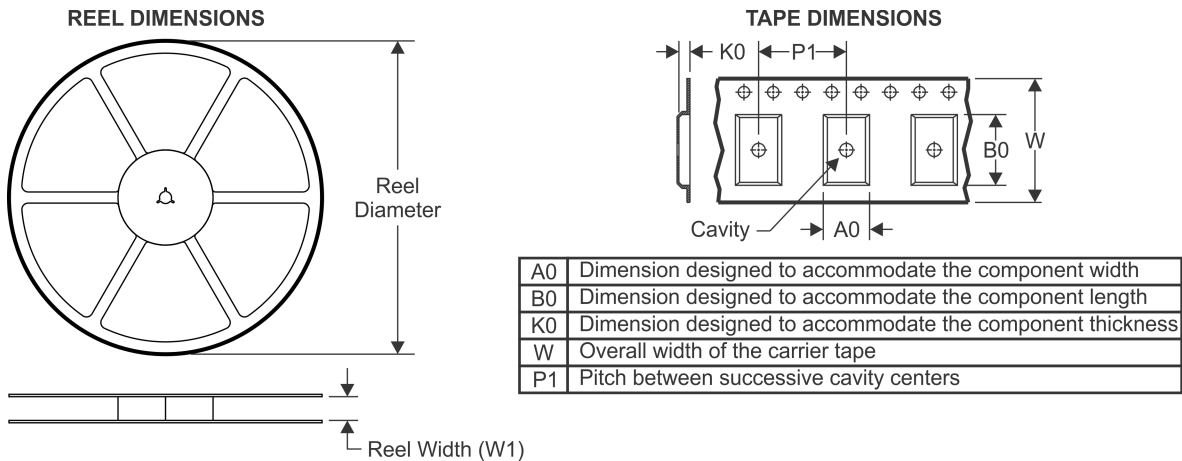
TAPE AND REEL INFORMATION

QUADRANT ASSIGNMENTS FOR PIN 1 ORIENTATION IN TAPE

*All dimensions are nominal

Device	Package Type	Package Drawing	Pins	SPQ	Reel Diameter (mm)	Reel Width W1 (mm)	A0 (mm)	B0 (mm)	K0 (mm)	P1 (mm)	W (mm)	Pin1 Quadrant
LMP8480MM-T/NOPB	VSSOP	DGK	8	1000	178.0	12.4	5.3	3.4	1.4	8.0	12.0	Q1
LMP8480MME-S/NOPB	VSSOP	DGK	8	250	178.0	12.4	5.3	3.4	1.4	8.0	12.0	Q1
LMP8480MME-T/NOPB	VSSOP	DGK	8	250	178.0	12.4	5.3	3.4	1.4	8.0	12.0	Q1
LMP8480MMX-S/NOPB	VSSOP	DGK	8	3500	330.0	12.4	5.3	3.4	1.4	8.0	12.0	Q1
LMP8480MMX-T/NOPB	VSSOP	DGK	8	3500	330.0	12.4	5.3	3.4	1.4	8.0	12.0	Q1
LMP8481MM-H/NOPB	VSSOP	DGK	8	1000	178.0	12.4	5.3	3.4	1.4	8.0	12.0	Q1
LMP8481MM-S/NOPB	VSSOP	DGK	8	1000	178.0	12.4	5.3	3.4	1.4	8.0	12.0	Q1
LMP8481MM-T/NOPB	VSSOP	DGK	8	1000	178.0	12.4	5.3	3.4	1.4	8.0	12.0	Q1
LMP8481MME-H/NOPB	VSSOP	DGK	8	250	178.0	12.4	5.3	3.4	1.4	8.0	12.0	Q1
LMP8481MME-S/NOPB	VSSOP	DGK	8	250	178.0	12.4	5.3	3.4	1.4	8.0	12.0	Q1
LMP8481MME-T/NOPB	VSSOP	DGK	8	250	178.0	12.4	5.3	3.4	1.4	8.0	12.0	Q1
LMP8481MMX-H/NOPB	VSSOP	DGK	8	3500	330.0	12.4	5.3	3.4	1.4	8.0	12.0	Q1
LMP8481MMX-S/NOPB	VSSOP	DGK	8	3500	330.0	12.4	5.3	3.4	1.4	8.0	12.0	Q1
LMP8481MMX-T/NOPB	VSSOP	DGK	8	3500	330.0	12.4	5.3	3.4	1.4	8.0	12.0	Q1

TAPE AND REEL BOX DIMENSIONS

*All dimensions are nominal

Device	Package Type	Package Drawing	Pins	SPQ	Length (mm)	Width (mm)	Height (mm)
LMP8480MM-T/NOPB	VSSOP	DGK	8	1000	210.0	185.0	35.0
LMP8480MME-S/NOPB	VSSOP	DGK	8	250	210.0	185.0	35.0
LMP8480MME-T/NOPB	VSSOP	DGK	8	250	210.0	185.0	35.0
LMP8480MMX-S/NOPB	VSSOP	DGK	8	3500	367.0	367.0	35.0
LMP8480MMX-T/NOPB	VSSOP	DGK	8	3500	367.0	367.0	35.0
LMP8481MM-H/NOPB	VSSOP	DGK	8	1000	210.0	185.0	35.0
LMP8481MM-S/NOPB	VSSOP	DGK	8	1000	210.0	185.0	35.0
LMP8481MM-T/NOPB	VSSOP	DGK	8	1000	210.0	185.0	35.0
LMP8481MME-H/NOPB	VSSOP	DGK	8	250	210.0	185.0	35.0
LMP8481MME-S/NOPB	VSSOP	DGK	8	250	210.0	185.0	35.0
LMP8481MME-T/NOPB	VSSOP	DGK	8	250	210.0	185.0	35.0
LMP8481MMX-H/NOPB	VSSOP	DGK	8	3500	367.0	367.0	35.0
LMP8481MMX-S/NOPB	VSSOP	DGK	8	3500	367.0	367.0	35.0
LMP8481MMX-T/NOPB	VSSOP	DGK	8	3500	367.0	367.0	35.0

IMPORTANT NOTICE

Texas Instruments Incorporated and its subsidiaries (TI) reserve the right to make corrections, enhancements, improvements and other changes to its semiconductor products and services per JESD46, latest issue, and to discontinue any product or service per JESD48, latest issue. Buyers should obtain the latest relevant information before placing orders and should verify that such information is current and complete. All semiconductor products (also referred to herein as "components") are sold subject to TI's terms and conditions of sale supplied at the time of order acknowledgment.

TI warrants performance of its components to the specifications applicable at the time of sale, in accordance with the warranty in TI's terms and conditions of sale of semiconductor products. Testing and other quality control techniques are used to the extent TI deems necessary to support this warranty. Except where mandated by applicable law, testing of all parameters of each component is not necessarily performed.

TI assumes no liability for applications assistance or the design of Buyers' products. Buyers are responsible for their products and applications using TI components. To minimize the risks associated with Buyers' products and applications, Buyers should provide adequate design and operating safeguards.

TI does not warrant or represent that any license, either express or implied, is granted under any patent right, copyright, mask work right, or other intellectual property right relating to any combination, machine, or process in which TI components or services are used. Information published by TI regarding third-party products or services does not constitute a license to use such products or services or a warranty or endorsement thereof. Use of such information may require a license from a third party under the patents or other intellectual property of the third party, or a license from TI under the patents or other intellectual property of TI.

Reproduction of significant portions of TI information in TI data books or data sheets is permissible only if reproduction is without alteration and is accompanied by all associated warranties, conditions, limitations, and notices. TI is not responsible or liable for such altered documentation. Information of third parties may be subject to additional restrictions.

Resale of TI components or services with statements different from or beyond the parameters stated by TI for that component or service voids all express and any implied warranties for the associated TI component or service and is an unfair and deceptive business practice. TI is not responsible or liable for any such statements.

Buyer acknowledges and agrees that it is solely responsible for compliance with all legal, regulatory and safety-related requirements concerning its products, and any use of TI components in its applications, notwithstanding any applications-related information or support that may be provided by TI. Buyer represents and agrees that it has all the necessary expertise to create and implement safeguards which anticipate dangerous consequences of failures, monitor failures and their consequences, lessen the likelihood of failures that might cause harm and take appropriate remedial actions. Buyer will fully indemnify TI and its representatives against any damages arising out of the use of any TI components in safety-critical applications.

In some cases, TI components may be promoted specifically to facilitate safety-related applications. With such components, TI's goal is to help enable customers to design and create their own end-product solutions that meet applicable functional safety standards and requirements. Nonetheless, such components are subject to these terms.

No TI components are authorized for use in FDA Class III (or similar life-critical medical equipment) unless authorized officers of the parties have executed a special agreement specifically governing such use.

Only those TI components which TI has specifically designated as military grade or "enhanced plastic" are designed and intended for use in military/aerospace applications or environments. Buyer acknowledges and agrees that any military or aerospace use of TI components which have **not** been so designated is solely at the Buyer's risk, and that Buyer is solely responsible for compliance with all legal and regulatory requirements in connection with such use.

TI has specifically designated certain components as meeting ISO/TS16949 requirements, mainly for automotive use. In any case of use of non-designated products, TI will not be responsible for any failure to meet ISO/TS16949.

Products

Audio	www.ti.com/audio
Amplifiers	amplifier.ti.com
Data Converters	dataconverter.ti.com
DLP® Products	www.dlp.com
DSP	dsp.ti.com
Clocks and Timers	www.ti.com/clocks
Interface	interface.ti.com
Logic	logic.ti.com
Power Mgmt	power.ti.com
Microcontrollers	microcontroller.ti.com
RFID	www.ti-rfid.com
OMAP Applications Processors	www.ti.com/omap
Wireless Connectivity	www.ti.com/wirelessconnectivity

Applications

Automotive and Transportation	www.ti.com/automotive
Communications and Telecom	www.ti.com/communications
Computers and Peripherals	www.ti.com/computers
Consumer Electronics	www.ti.com/consumer-apps
Energy and Lighting	www.ti.com/energy
Industrial	www.ti.com/industrial
Medical	www.ti.com/medical
Security	www.ti.com/security
Space, Avionics and Defense	www.ti.com/space-avionics-defense
Video and Imaging	www.ti.com/video

TI E2E Community

e2e.ti.com